

Part Number—D903XX
Brushless DC Axial Fan
Application: Cooling elec-
tronics in business ma-
chines, power supplies, in-
strumentation etc.

AC MOTORS

Arkansas General Industries

"RELY ON GI"



ISO 9001 CERTIFIED



Brushless DC Axial Fan
5V, 12V, 24V, 48V
36CFM or 46 CFM Models available
CCW Rotation viewed from impeller side
Dynamically balanced to 0.4 gm-mm
24 gauge lead wire, 150mm long
Reinforced plastic impeller and housing

Arkansas General Industries

102 Miller St
P.O. Box 260
Bald Knob
AR 72010

Phone: 501-724-3227
Fax: 501-724-5915
Email: info@agimotors.com
www.agimotors.com

Part Number—D903 XX
 Brushless DC Axial Fan
 Application: Cooling elec-
 tronics in business ma-
 chines, power supplies etc.

Arkansas General Industries

"RELY ON GI"



ISO 9001 CERTIFIED

NOTE: Sleeve Bearing Designs are no longer available

AC 92 x 92 x 32 - AXIAL FAN

BRUSHLESS DC FANS

FEATURES :

- Reinforced Plastic Impeller and Housing
- Air input over struts.
- CCW rotation viewed from impeller side.
- Long, maintenance free life.
- 5V to 48V
- Mounting position independent.
- Dynamically balanced to 0.4 gm-mm.
- Electronically Commutated Brushless DC Motor
- 35 to 46 CFM Airflow.
- Reverse voltage polarity protection.
- Low power consumption.
- Lead wire – SWG 24, 150mm.

OPTIONS :

- Ball or sleeve Bearing.
- Locked rotor protection.
- Locked rotor power down with autorestart.
- Tachometer output.
- Reverse Airflow.
- Dual voltage fans : 5/12V, 12/24V 24/48V

QUALITY ASSURANCE :

- Inline inspection, testing and recording.
- 100% Final testing.
- 100% preshipment Burn-In.

TEST FACILITIES :

- Pressure Vs Airflow per AMCA210.
- Acoustic measurement in full octave band.
- Dry heat, wet heat.
- SFHP motor test facilities for AC and DC motor.
- Endurance test set-up.

Part No. System

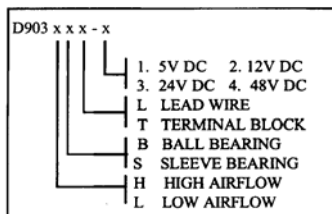

- Ball Bearing
- Sleeve Bearing

AC 92 x 92 x 32mm. 46CFM

- D903HB - 1/5V/ ●/38dBA/ -10..+80°C
 - D903HS - 1/5V/ ○/35dBA/ -10..+70°C
 - D903HB - 2/12V/ ●/38dBA/ -10..+80°C
 - D903HS - 2/12V/ ○/35dBA/ -10..+70°C
 - D903HB - 3/24V/ ●/38dBA/ -10..+80°C
 - D903HS - 3/24V/ ○/35dBA/ -10..+70°C
 - D903HB - 4/48V/ ●/38dBA/ -10..+80°C
 - D903HS - 4/48V/ ○/35dBA/ -10..+70°C
- Voltage Range ... ± 20%
 Input Power ... 2.6W
 Speed ... 3300 rpm
 Weight ... 150 gms.

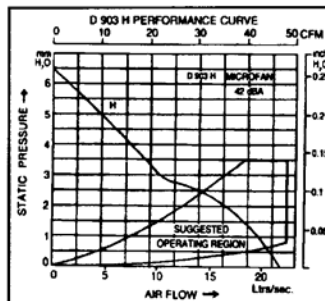
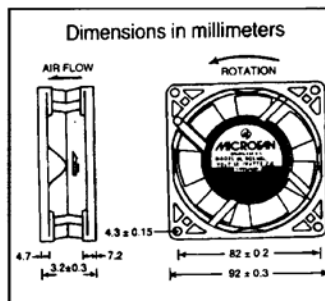

AC 92 x 92 x 32mm. 36CFM

- D903HB - 1/5V/ ●/30dBA/ -10..+80°C
 - D903HS - 1/5V/ ○/29dBA/ -10..+70°C
 - D903HB - 2/12V/ ●/30dBA/ -10..+80°C
 - D903HS - 2/12V/ ○/29dBA/ -10..+70°C
 - D903HB - 3/24V/ ●/30dBA/ -10..+80°C
 - D903HS - 3/24V/ ○/29dBA/ -10..+70°C
 - D903HB - 4/48V/ ●/30dBA/ -10..+80°C
 - D903HS - 4/48V/ ○/29dBA/ -10..+70°C
- Voltage Range ... ±20%
 Input Power ... 1.6W
 Speed ... 2500 rpm
 Weight ... 150 gms.

